

GR-1000XL



100 Ton (90.7 Metric Tons) Capacity

HYDRAULIC ROUGH TERRAIN CRANE

DIMENSIONS

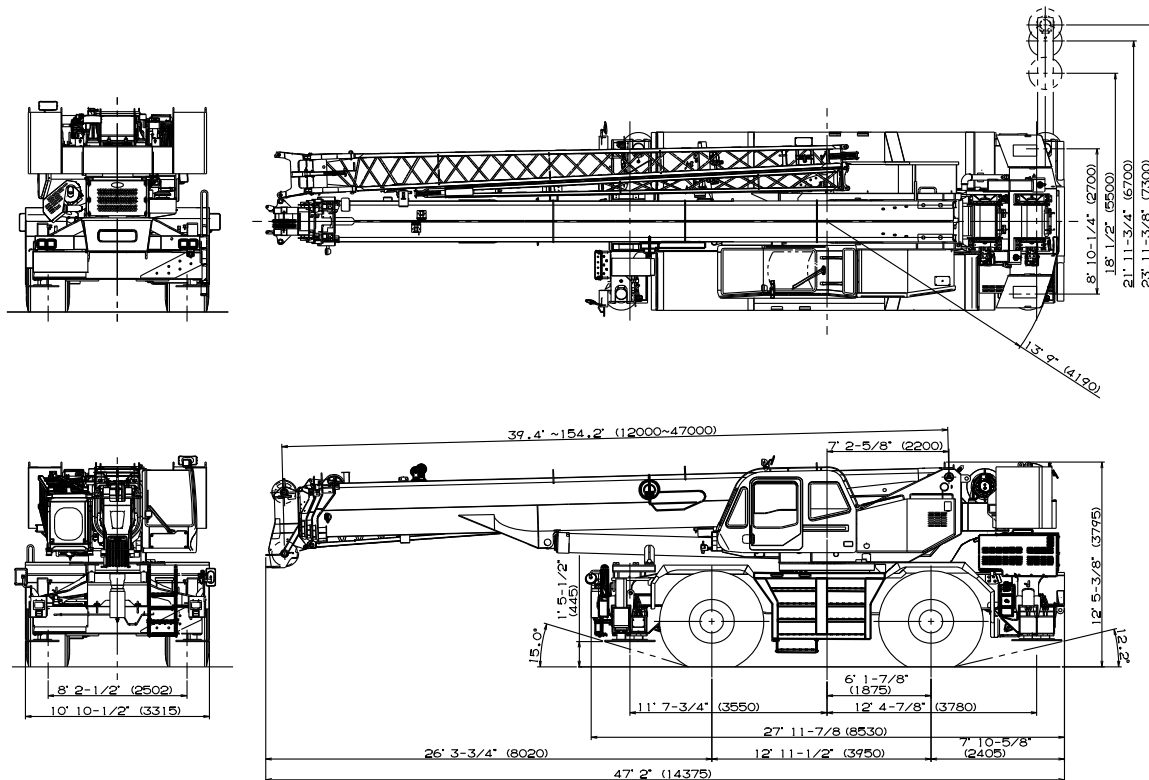

Note : Dimension is with boom angle at -1.5 degree.

() Reference dimensions in mm.

GENERAL DIMENSIONS

	Feet	Meters
Turning radius (29.5 - 25 Tires)		
4 wheel steer	22' 4"	6.8
2 wheel steer	39' 1"	11.9
Tail swing of counterweight	13' 9"	4.19

	Feet	Meters
Overall length	approx. 47' 2"	14,375
Overall width	approx. 10' 10-1/2"	3,315
Overall height	approx. 12' 5"-3/8"	3,795
Carrier length	approx. 28' 1-7/8"	8,530
for traveling		

CRANE SPECIFICATIONS

BOOM

Five section full power synchronized telescoping boom, 39.4'~154.2' (12.0 m~47.0 m), of round box construction with 7 sheaves, 17-5/16" (0.44 m) root diameter, at boom head. The synchronization system consists of two telescope cylinders, an extension cable and retraction cable. Hydraulic cylinder fitted with holding valve. Two easily removable wire rope guards, rope dead end provided on both sides of boom head. Boom telescope sections are supported by wear pads both vertically and horizontally. Extension speed 114.8' in 160 seconds.

BOOM ELEVATION - By a double acting hydraulic cylinder with holding valve. Elevation -1.5°~80.5°, combination controls for hand or foot operation. Boom angle indicator. Automatic speed reduction and slow stop function. Boom raising speed 20° to 60° in 46 seconds.

JIB - Two stage bi-fold lattice type, 3.5°, 25° or 45° offset (tilt type). Single sheave, 15-5/8" (0.396 m) root diameter, at the head of both jib sections. Stored alongside base boom section. Jib length is 33.2' (10.1 m) or 58.1' (17.7 m). Assistant cylinders for mounting and stowing, controlled at right side of superstructure. Self stowing jib mounting pins.

AUXILIARY LIFTING SHEAVE (SINGLE TOP)
Single sheave, 15-5/8" (0.396 m) root diameter. Mounted to main boom head for single line work (stowable).

ANTI-TWO BLOCK - Pendant type over-winding cut out device with audio-visual (FAILURE lamp/BUZZER) warning system.

SLEWING

Hydraulic axial piston motor through planetary slewing speed reducer. Continuous 360° full circle slewing on ball bearing turn table at 1.5 min⁻¹ (rpm). Equipped with manually locked/released slewing brake. A 360° positive slewing lock for pick and carry and travel modes, manually engaged in cab. Twin slewing system: Free slewing or lock slewing controlled by selector switch on front console.

HOIST

MAIN HOIST - Variable speed type with grooved drum driven by hydraulic axial piston motor through speed reducer. Power load lowering and raising. Equipped with automatic brake (neutral brake) and counterbalance valve. Controlled independently of auxiliary hoist. Equipped with cable follower and drum rotation indicator.

DRUM - Grooved 14-1/4" (0.362 m) root diameter x 23-5/8" (0.6 m) wide. Wire rope: 830' of 3/4" diameter rope (253 m of 19 mm). Drum capacity: 997' (304 m) 7 layers. Maximum single line pull: 1st layer 20,000 lbs (9,090 kg). Maximum permissible line pull wire strength: 14,600 lbs (6,600 kg).

AUXILIARY HOIST - Variable speed type with grooved drum driven by hydraulic axial piston motor through speed reducer. Power load lowering and raising. Equipped with automatic brake (neutral brake) and counterbalance valve. Controlled independently of main hoist. Equipped with cable follower and drum rotation indicator.

DRUM - Grooved 14-1/4" (0.362 m) root diameter x 23-5/8" (0.6 m) wide. Wire rope: 456' of 3/4" diameter rope (139 m of 19 mm). Drum capacity: 997' (304 m) 7 layers. Maximum single line pull: 1st layer 20,000 lbs (9,090 kg). Maximum permissible line pull wire strength: 14,600 lbs (6,600 kg).

WIRE ROPE - Non-rotating 3/4" (19 mm) 7 X 35 class. Breaking Strength 72,800 lbs (33,000 kg)

HOOK BLOCKS

100 ton (90.7 metric ton)-8 sheaves with swivel hook and safety latch, for 3/4" (19 mm) wire rope (OPTIONAL).
7.3 ton (6.6 metric ton) - Weighted hook with swivel and safety latch, for 3/4" (19 mm) wire rope.

HYDRAULIC SYSTEM

PUMPS - Two variable piston pumps for crane functions. Tandem gear pump for steering, slewing and optional equipment. Powered by carrier engine. Pump disconnect for crane is engaged/ disengaged by rotary switch from operator's cab.

CONTROL VALVES - Multiple valves actuated by pilot pressure with integral pressure relief valves.

RESERVOIR - 202 gallon (763 lit.) capacity. External sight level gauge.

FILTRATION - BETA10=10 return filter, full flow with bypass protection, located inside of hydraulic reservoir. Accessible for easy replacement.

OIL COOLER - Air cooled fan type.

CAB AND CONTROLS

Both crane and drive operations can be performed from one cab mounted on rotating superstructure.

Left side, 1 man type, steel construction with sliding door access and safety glass windows opening at side. Door window is powered control. Windshield glass window and roof glass window are shatter-resistant. Tilt-telescoping steering wheel. Adjustable control lever stands for slewing, boom hoist, boom telescoping, auxiliary hoist and main hoist. Control lever stands can change neutral positions and tilt for easy access to cab. 3 way adjustable operator's seat with high back, headrest and armrest. Engine throttle knob. Foot operated controls: boom elevating boom telescoping, service brake and engine throttle. Hot water cab heater and air conditioning.

Dash-mounted engine start/stop, monitor lamps, cigarette lighter, drive selector switch, parking brake switch, steering mode select switch, power window switch, pump engaged/ disengaged switch, slewing brake switch, telescoping/auxiliary hoist select switch, outrigger controls, free slewing / lock slewing selector switch, eco-mode switch, high speed hoist (main / aux) switch and ashtray.

Instruments - Torque converter oil temperature, engine water temperature, air pressure, fuel, speedometer, tachometer, hour meter and odometer / tripmeter. Hydraulic oil pressure is monitored and displayed on the AML-C display panel.

Tadano electronic LOAD MOMENT INDICATOR system (AML-C) including:

- Control lever lockout function with audible and visual pre-warning
- Boom position indicator
- Outrigger state indicator
- Boom angle / boom length / jib offset angle / jib length / load radius / rated lifting capacities / actual loads read out
- Ratio of actual load moment to rated load moment indication
- Automatic Speed Reduction and Slow Stop function on boom elevation and slewing
- Working condition register switch
- Load radius / boom angle / tip height / slewing range preset function
- External warning lamp
- Tare function
- Fuel consumption monitor
- Main hoist / auxiliary hoist select
- Drum rotation indicator (audible and visible type) main and auxiliary hoist

TADANO AML-C monitors outrigger extended length and automatically programs the corresponding "RATED LIFTING CAPACITIES" table

Operator's right hand console includes transmission gear selector, slewing lock lever and sight level bubble. Upper console includes working light switch, roof washer and wiper switch, emergency outrigger set up key switch, jib equipped / removed select switch, eco mode switch, high speed hoist (main / aux) switch and air conditioning control switch.

NOTE: Each crane motion speed is based on unladen conditions.

CARRIER SPECIFICATIONS

TYPE - Rear engine, left hand steering, driving axle 2-way selected type by manual switch, 4 x 2 front drive, 4 x 4 front and rear drive.

FRAME - High tensile steel, all welded mono-box construction.

TRANSMISSION - Electronically controlled full automatic transmission. Torque converter driving full powershift with driving axle selector. 6 forward and 2 reverse speeds, constant mesh.

- 3 speeds - high range - 2 wheel drive; 4 wheel drive
- 3 speeds - low range - 4 wheel drive

TRAVEL SPEED - 22 mph (36 km/h)

GRADEABILITY (tanθ) - 94% (at stall), **57%

** Machine should be operated within the limit of engine design. (30°: Cummins QSB6.7)

AXLE - Front: Full floating type, steering and driving axle with planetary reduction. Rear: Full floating type, steering and driving axle with planetary reduction and non-spin rear differential.

STEERING - Hydraulic power steering controlled by steering wheel. Four steering modes available: 2 wheel front, 2 wheel rear, 4 wheel coordinated and 4 wheel crab .

SUSPENSION - Front: Rigid mounted to frame. Rear: Pivot mounted with hydraulic lockout device.

BRAKE SYSTEMS - Service: Air over hydraulic disc brakes on all 4 wheels. Parking / Emergency: Spring applied-air released brake acting on input shaft of front axle. Auxiliary: Electro-pneumatic operated exhaust brake.

TIRES - 29.5-25 34PR (OR) Air pressure: 57 psi (400 kPa)

OUTRIGGERS - Four hydraulic, beam and jack outriggers. Vertical jack cylinders equipped with integral holding valve. Each outrigger beam and jack is controlled independently from cab. Beams extend to 23' 11-3 / 8" (7.3 m) center-line and retract to within 10' 10-1 / 2" (3.315 m) overall width with floats. Outrigger jack floats are attached thus eliminating the need of manually attaching and detaching them. Controls and sight bubble located in superstructure cab. Four outrigger extension lengths are provided with corresponding "RATED LIFTING CAPACITIES" for crane duty in confined areas.

- Min. Extension 8' 10-1 / 4" (2.7 m) center to center
- Mid. Extension 18' 1 / 2" (5.5 m) center to center
- Mid. Extension 21' 11-3 / 4" (6.7 m) center to center
- Max. Extension 23' 11-3 / 8" (7.3 m) center to center

Float size (Diameter) 1' 11- 5 / 8" (0.6 m)

ENGINE

Model	Cummins QSB6.7 [Tier4]
Type	Direct injection diesel
No. of cylinders	6
Combustion	4 cycle, turbo charged and after cooled
BoreXStroke, in.(mm)	4.212 X 4.882 (107 X 124)
Displacement, cu. in (liters)	409 (6.700)
Air inlet heater	24 volt preheat
Air cleaner	Dry type, replaceable element
Oil filter	Full flow with replaceable element
Fuel filter	Full flow with replaceable element
Fuel tank, gal.(liters)	79.2 (300), right side of carrier
Cooling	Liquid pressurized, recirculating by-pass

Radiator	Fin and tube core, thermostat controlled
Fan, in.(mm)	Suction type, 9-blade, 28 (711) dia.
Starting	24 volt
Charging	24 volt system, negative ground
Battery	2-120 amp. Hour
Compressor, air, CFM(l /min)	17.0 CFM (481) at 2,400 rpm
Output, Max. HP(kW)	Gross 270 (201) at 2,000 rpm
Torque, Max. ft-lb (Nm)	730 (990) at 1,500 rpm
Capacity, gal.(liters)	
Cooling water	2.7 (10)
Lubrication	4.0 (15)
Fuel	79.2 (300)
DEF / AdBlue	10.0 (38)

STANDARD EQUIPMENT

- Five section full power partially synchronized boom
39.4' ~ 154.2' (12.0 m ~ 47.0 m)
- 33.2' or 58.1' (10.1 m or 17.7 m) bi-fold lattice jib (tilt type)
with 3.5°, 25° or 45° pinned offsets and self storing pins.
- Quick reeving type bi-fold jib
- Anti-Two block device (overwind cutout)
- Mirror for main and auxiliary hoists
- Work lights
- Variable speed main hoist with grooved drum, cable follower,
drum rotation indicator (audible, visible and thumper type)
and 820' of 3/4" cable.
- Variable speed auxiliary hoist with grooved drum, cable follower,
drum rotation indicator (audible, visible and thumper type)
and 456' of 3/4" cable.
- Auxiliary lifting sheave (single top) stowable
- 2-speed hoist
- Tadano twin slewing system and 360° positive slewing lock
- Positive control
- Hydraulic oil cooler
- 3 way adjustable cloth seat with armrests, high back
and seat belt
- Tilt-telescoping steering wheel
- Tinted safety glass and sun visor
- Front windshield wiper and washer
- Roof window wiper and washer
- Power window (cab door)
- Cigarette lighter and ashtray
- Cab floor mat
- Pump disconnect in operator's cab
- Air conditioner (hot water heater and cooler)
- Full instrumentation package
- Self centering finger control levers with pilot control
- Control pedals for boom elevating and boom telescoping
- Low oil pressure / high water temp. warning device (visual)
- Rear steer centering light
- Air cleaner dust indicator
- Tadano electronic load moment indicator system (AML-C)
- Boom angle indicator
- Outrigger extension length detector
- Electronic crane monitoring system
- Rear view mirrors (right and left side)
- Fenders
- Air dryer
- Complete highway light package
- Towing hooks-Front and rear
- Hook block tie down (front bumper)
- Weighted hook storage compartment
- Halogen head lamp
- Independently controlled outriggers
- Four outrigger extension positions
- Self-storing outrigger pads
- Electronic controlled automatic transmission driven
by torque converter
- 4 X 4 X 4 drive / steer
- Non-spin rear differential
- Automatic rear axle oscillation lockout system
- 29.5-25 34 PR tires
- Disc brakes
- Water separator with filter (high filtration)
- Back-up alarm
- 24 volt electric system
- Tool storage compartment
- Tire inflation kit
- Cummins QSB6.7 turbo charged
after cooled engine (270 HP) with exhaust brake
- Engine over-run alarm
- Lifting eyes
- Telematics(machine data logging and monitoring system)
with HELLO-NET via internet
(availability depends on countries)
- Fuel consumption monitor
- Eco mode system
- Self-removable counterweight
- Emergency steering system
- 7.3 ton (6.6 metric ton) hook with swivel
- Radiator cover
- 100 ton (90.7 metric ton) - 8 sheave with swivel hook and
safety latch for 3/4" (19 mm) wire rope

HOISTING PERFORMANCE

LINE SPEEDS AND PULLS

Layer	Main or auxiliary hoist - 14'-1 / 4" (0.362 m) drum							
	Line speeds ¹				Line pulls Available ²			
	Low		High		Low		High	
	F.P.M	m / min	F.P.M	m / min	Lbs.	kgf	Lbs.	kgf
1st	278	84	387	118	20,000	9,090	14,400	6,520
2nd	302	92	421	128	18,100	8,230	13,000	5,900
3rd	327	99	456	139	16,600	7,520	11,900	5,390
4th	352	107	491	149	15,300	6,920	10,900	4,960
5th	377	115	526	160	14,100	6,410	10,100	4,600
6th	402	122	560	170	13,200	5,970	9,400	4,280
7th ³	427	130	595	181	12,300	5,590	8,800	4,010

- Maximum permissible line pull wire strength
14,600 lbs (6,600 kg) with 7 X 35 class rope.

¹ Line speeds based only on hook block, not loaded.

² Developed by machinery with each layer of wire rope, but not based on rope strength or other limitation in machinery or equipment.

³ Seventh layer of wire rope are not recommended for hoisting operations.

DRUM WIRE ROPE CAPACITIES

Wire rope layer	Main and auxiliary drum grooved lagging			
	30 / 4" (19 mm) wire rope			
	Rope per layer		Total wire rope	
	Feet	Meters	Feet	Meters
1	112.2	34.2	112.2	34.2
2	122.3	37.3	234.5	71.5
3	132.2	40.3	366.8	111.8
4	142.3	43.4	509.1	155.2
5	152.2	46.4	661.4	201.6
6	162.4	49.5	823.8	251.1
7	172.5	52.6	996.4	303.7

DRUM DIMENSIONS

	Inch	mm
Root diameter	14-1 / 4"	362
Length	23-5 / 8"	600
Flange diameter	25-7 / 8"	657

GR-1000XL WORKING RANGE CHART

360° ROTATION

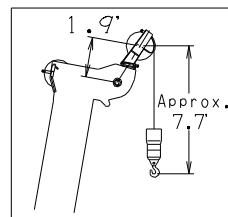
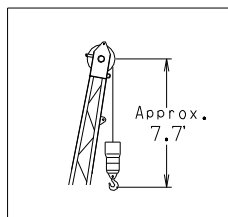
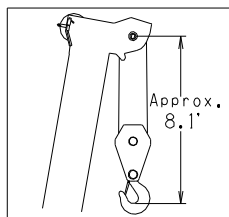
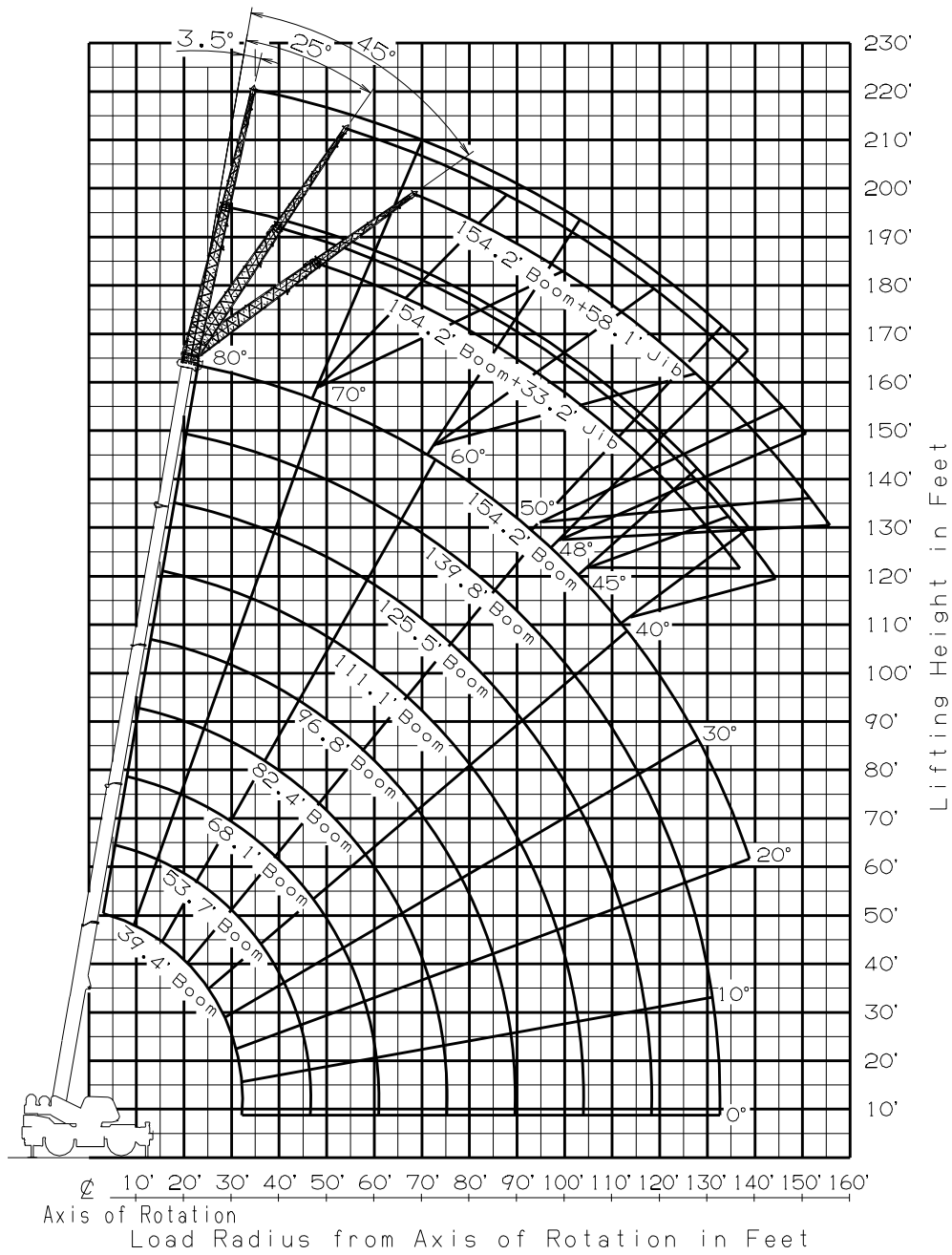

NOTE: 1. Boom and jib geometry shown are for unloaded condition and machine standing level on firm supporting surface.
 Boom deflection and subsequent radius and boom angle change must be accounted for when applying load to hook.

GR-1000XL WORKING RANGE CHART SMART CHART

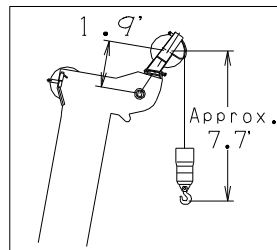
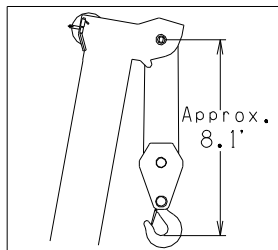
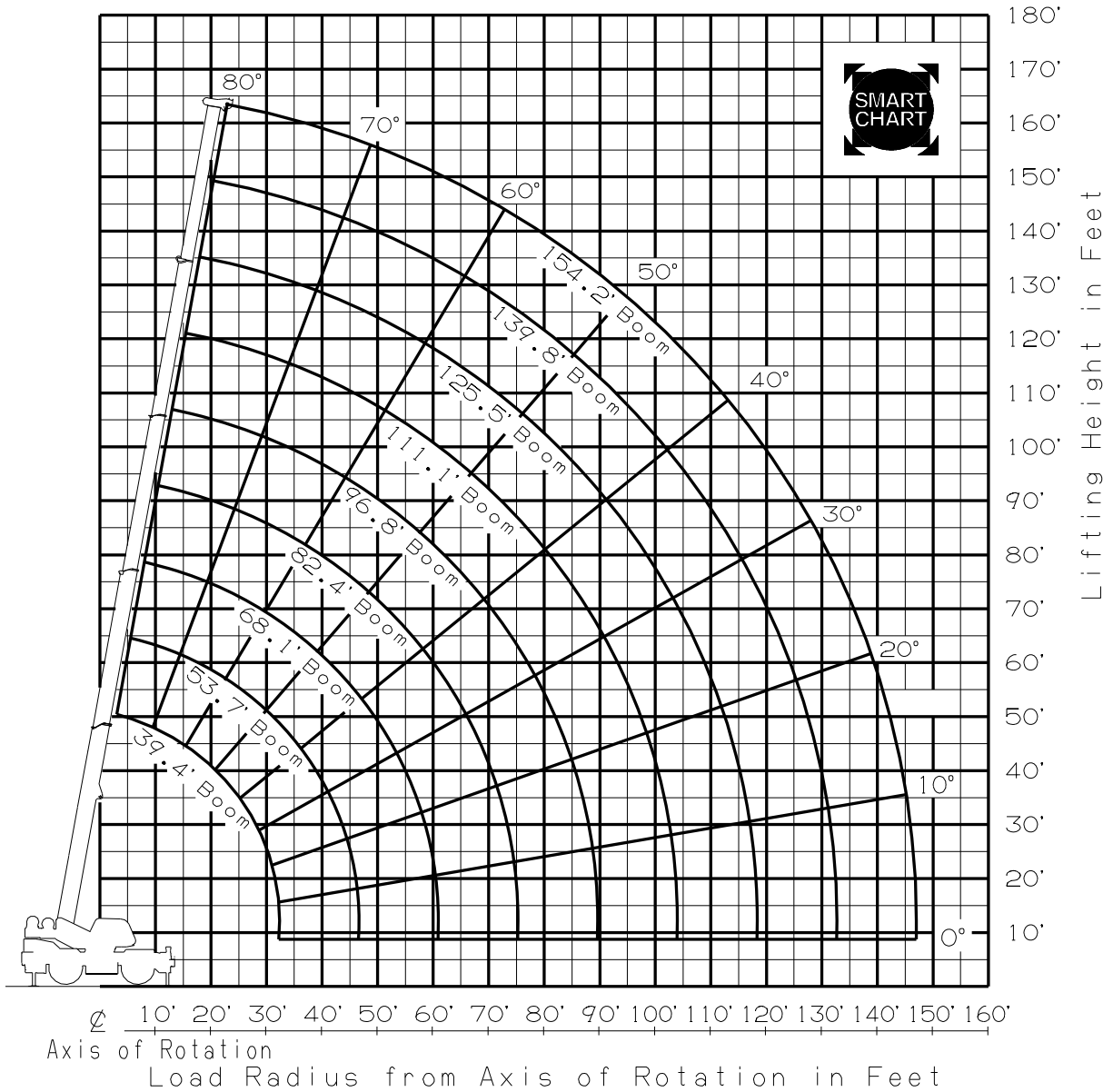

NOTE: 1. Boom geometry shown is for unloaded condition and machine standing level on firm supporting surface. Boom deflection and subsequent radius and boom angle change must be accounted for when applying load to hook.

GR-1000XL RATED LIFTING CAPACITIES (IN POUNDS)

COUNTERWEIGHT 22,000 lbs (10 t) ON OUTRIGGERS FULLY EXTENDED 23' 11-3 / 8" (7.3 m) SPREAD SMART CHART																															
B	A 39.4'		53.7'		68.1' (20.8 m)		82.4' (25.1 m)		96.8' (29.5 m)		111.1' (33.9 m)		125.5' (38.3 m)		139.8' (42.6 m)		154.2'														
	C	(12 m)	C	(16.4 m)	C	C	C	C	C	C	C	C	C	C	C	C	C	(47 m)													
8'	74	200,000	78	102,700																											
10'	71	180,000	76	102,700	79	90,200	79	40,100																							
12'	68	157,900	74	102,700	78	90,200	77	40,100																							
15'	62	132,300	70	102,700	75	89,900	75	40,100	78	42,500	78	35,500																			
20'	53	99,700	65	99,100	71	76,100	70	40,100	74	42,500	74	35,500	77	40,100	77	33,300	79	35,500	79	32,200											
25'	42	76,900	58	76,200	66	65,600	66	40,100	71	42,500	71	35,500	74	40,100	74	33,300	77	35,500	77	32,200	79	33,300	79	28,700							
30'	25	50,700	51	57,900	61	57,000	62	40,100	67	42,500	67	35,500	71	40,100	71	33,300	74	35,500	74	30,200	77	33,300	77	26,300	78	26,700	78	24,300			
35'			44	45,800	56	44,900	56	40,100	63	42,500	63	35,500	68	39,500	68	31,600	72	35,100	71	27,300	74	30,900	74	24,000	77	26,700	76	24,100	78	20,900	
40'			35	37,200	51	36,300	50	40,100	59	38,400	59	35,500	65	35,600	65	29,300	69	32,000	69	24,900	72	28,400	72	22,000	75	25,300	75	22,300	76	20,900	
45'			24	30,800	46	29,900	44	35,600	55	31,900	55	35,500	62	33,000	62	26,500	66	29,300	66	22,900	70	26,100	69	20,200	73	23,500	72	20,700	74	20,700	
50'					40	24,900	37	30,500	51	26,800	50	31,200	58	28,000	58	24,100	63	26,900	63	21,800	67	24,100	67	18,700	70	21,800	70	19,300	73	19,400	
55'					33	20,800	28	26,300	46	22,600	45	27,000	55	23,500	55	22,200	60	24,400	60	19,900	65	22,300	65	17,400	68	20,200	68	18,000	71	18,300	
60'					25	17,200	15	22,500	41	18,900	40	23,200	51	19,900	51	20,400	57	20,700	57	18,200	62	20,700	62	16,500	66	18,800	66	16,800	69	17,200	
65'									35	16,000	33	20,200	46	16,900	46	18,900	54	17,700	54	16,600	59	18,000	59	15,000	64	17,600	64	15,800	67	16,100	
70'									28	13,500	25	17,700	41	14,500	42	17,500	50	15,200	50	15,300	56	15,600	57	13,800	61	16,100	61	14,800	65	15,100	
75'									16	11,600	11	15,700	36	12,500	36	15,900	47	13,200	47	14,200	54	13,600	54	14,100	59	14,100	59	14,100	63	14,200	
80'													30	10,800	30	14,100	43	11,500	43	13,100	50	11,800	51	11,700	56	12,300	56	13,200	60	12,600	
85'													22	9,300	22	12,600	38	10,000	39	12,200	47	10,300	47	10,900	53	10,800	54	11,900	58	11,100	
90'																	33	8,700	34	11,400	44	9,100	44	10,100	51	9,500	51	10,600	56	9,800	
95'																	27	7,600	27	10,400	40	7,900	40	9,400	48	8,400	48	9,500	53	8,600	
100'																	20	6,600	20	9,400	36	6,900	36	8,800	45	7,400	45	8,500	51	7,600	
105'																					31	6,100	31	8,300	41	6,500	41	7,600	48	6,700	
110'																					25	5,300	26	7,800	38	5,700	38	6,800	45	6,000	
115'																					18	4,600	18	7,200	33	5,000	34	6,100	42	5,200	
120'																									29	4,400	29	5,400	39	4,600	
125'																									24	3,800	23	4,900	35	4,000	
130'																									16	3,300	16	4,400	31	3,500	
135'																														27	3,000
140'																														22	2,600
D	0																														
Telescoping conditions (%)																															
Telescoping mode	I, II	I	I	II	I	II	I	II	I	II	I	II	I	II	I	II	I, II														
2nd boom	0	50	100	0	100	0	100	0	100	0	100	0	100	0	100	50	100														
3rd boom	0	0	0	33	16	50	33	66	50	83	66	100	83	100	83	100	100														
4th boom	0	0	0	33	16	50	33	66	50	83	66	100	83	100	83	100	100														
Top boom	0	0	0	33	16	50	33	66	50	83	66	100	83	100	83	100	100														

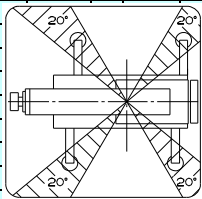

COUNTERWEIGHT 22,000 lbs (10 t) LIFTING CAPACITIES AT ZERO DEGREE BOOM ANGLE ON OUTRIGGERS FULLY EXTENDED 23' 11-3 / 8" (7.3 m) SPREAD SMART CHART																												
C	A 39.4'		53.7'		68.1'		68.1'		82.4'		82.4'		96.8'		96.8'		111.1'		111.1'		125.5'		125.5'		139.8'		139.8'	
	B	(12 m)	B	(16.4 m)	B	(20.8 m)	B	(20.8 m)	B	(25.1 m)	B	(25.1 m)	B	(29.5 m)	B	(29.5 m)	B	(33.9 m)	B	(33.9 m)	B	(38.3 m)	B	(38.3 m)	B	(42.6 m)	B	(42.6 m)
0	32.1'	45,500	47.8'	23,900	63.0'	12,000	61.1'	20,600	76.6'	9,500	75.4'	15,100	89.8'	5,400	89.7'	8,800	103.8'	4,100	103.5'	7,100	117.8'	3,000	117.0'	6,000	131.7'	2,700	130.8'	4,000
Telescoping mode	I, II	I	I	II	I	II	I	II	I	II	I	II	I	II	I	II	I	II	I	II	I	II	I	II	I	II	I	II

- A : Boom length in feet
- B : Load radius in feet
- C : Loaded boom angle (°)
- D : Minimum boom angle (°) for indicated length (no load)

NOTE: The lifting capacity data stored in the LOAD MOMENT INDICATOR (AML-C) is based on the standard number of parts of line listed in the chart.
Standard number of parts of line for each boom length should be according to the following table.

Boom length in feet (meters)	39.4' (12 m)	39.4' to 68.1' (12 m to 20.8 m)		68.1' to 154.2' (20.8 m to 47 m)		Single top Jib
Telescoping mode	I, II	I	II	I, II		I, II
Number of parts of line	16	8	4	4		1

GR-1000XL RATED LIFTING CAPACITIES (IN POUNDS)

COUNTERWEIGHT 22,000 lbs (10 t) ON OUTRIGGERS MID EXTENDED 21' 11-3 / 4" (6.7 m) SPREAD 360° ROTATION																														
A B	39.4'		53.7'		68.1' (20.8 m)		82.4' (25.1 m)		96.8' (29.5 m)		111.1' (33.9 m)		125.5' (38.3 m)		139.8' (42.6 m)		154.2'													
	C	(12 m)	C	(16.4 m)	C	C	C	C	C	C	C	C	C	C	C	C	C	(47 m)												
8'	73	200,000	78	102,700																										
10'	70	175,700	76	102,700	80	90,200	79	40,100																						
12'	67	153,600	74	102,700	78	90,200	77	40,100																						
15'	61	128,200	70	102,700	75	89,900	75	40,100	78	42,500	78	35,500																		
20'	52	94,800	64	98,000	71	75,000	70	40,100	74	42,500	74	35,500	77	40,100	77	33,300	79	35,500	79	32,200										
25'	41	67,800	58	65,800	66	59,500	65	40,100	71	42,500	70	35,500	74	40,100	74	33,300	77	35,500	77	32,200	79	33,300	79	28,700						
30'	25	46,900	50	45,400	61	44,400	60	40,100	67	42,500	67	35,500	71	40,100	71	33,300	74	35,500	74	30,200	77	33,300	77	26,300	79	26,700	79	24,300		
35'			42	33,400	56	32,200	55	36,200	63	34,300	63	35,500	68	35,400	68	31,600	72	35,100	72	27,300	74	30,900	74	24,000	77	26,700	77	24,100	78	20,900
40'			33	25,400	50	24,400	50	30,400	58	26,400	58	31,100	65	27,500	65	29,300	69	28,300	69	24,900	72	28,400	72	22,000	75	25,300	75	22,300	77	20,900
45'			18	19,800	44	18,900	43	24,600	54	20,800	54	25,300	61	21,800	61	25,600	65	22,600	66	22,900	69	23,100	69	20,200	72	23,500	73	20,700	75	20,700
50'					37	14,800	36	20,300	49	16,700	49	21,000	57	17,700	57	21,300	62	18,400	63	20,400	67	18,900	67	18,700	70	19,300	71	19,300	73	19,400
55'					28	11,600	27	17,000	44	13,400	44	17,600	53	14,500	53	18,000	59	15,200	60	18,000	64	15,700	64	17,400	68	16,100	68	17,300	71	16,400
60'					13	9,200	12	14,300	38	10,800	38	14,900	49	11,900	49	15,400	56	12,600	56	15,600	64	13,100	61	15,700	65	13,400	66	14,700	69	13,700
65'								32	8,700	32	12,800	45	9,700	45	13,200	52	10,500	53	13,400	58	11,000	59	13,600	63	11,300	63	12,500	67	11,600	
70'									23	7,000	23	11,000	40	8,000	40	11,400	49	8,700	49	11,600	55	9,200	56	11,800	60	9,600	61	10,700	64	9,900
75'								5	5,600	5	9,500	35	6,500	35	9,900	45	7,200	45	10,100	52	7,700	53	10,300	57	8,100	58	9,300	62	8,400	
80'												29	5,200	29	8,600	41	5,900	41	8,800	49	6,400	49	9,000	55	6,800	55	8,000	60	7,100	
85'												21	4,200	21	7,500	36	4,800	37	7,700	46	5,300	46	7,800	52	5,700	52	6,900	57	6,000	
90'																31	3,900	32	6,700	42	4,400	42	6,900	49	4,700	49	5,900	55	5,000	
95'																25	3,100	25	5,900	38	3,500	38	6,000	46	3,900	46	5,000	52	4,200	
100'																16	2,400	16	5,200	34	2,800	34	5,200	43	3,200	43	4,300	50	3,400	
105'																			29	2,100	29	4,600	40	2,500	40	3,600	47	2,800		
110'																			24	1,600	23	4,000	36	1,900	36	3,000	44	2,200		
115'																					14	3,500	32	1,400	32	2,400	41	1,600		
120'																										27	2,000			
125'																										21	1,600			
D	0															27	11	38												
Telescoping conditions (%)																														
Telescoping mode	I, II	I	I	II	I	II	I	II	I	II	I	II	I	II	I	II	I, II													
2nd boom	0	50	100	0	100	0	100	0	100	0	100	0	100	0	100	50	100													
3rd boom	0	0	0	33	16	50	33	66	50	83	66	100	83	100	83	100	100													
4th boom	0	0	0	33	16	50	33	66	50	83	66	100	83	100	83	100	100													
Top boom	0	0	0	33	16	50	33	66	50	83	66	100	83	100	83	100	100													

COUNTERWEIGHT 22,000 lbs (10 t) LIFTING CAPACITIES AT ZERO DEGREE BOOM ANGLE ON OUTRIGGERS MID EXTENDED 21' 11-3 / 4" (6.7 m) SPREAD 360° ROTATION																								
A C	39.4'		53.7'		68.1'		68.1'		82.4'		82.4'		96.8'		96.8'		111.1'		111.1'		125.5'		125.5'	
	B	(12 m)	B	(16.4 m)	B	(20.8 m)	B	(20.8 m)	B	(25.1 m)	B	(25.1 m)	B	(29.5 m)	B	(29.5 m)	B	(33.9 m)	B	(33.9 m)	B	(38.3 m)	B	(38.3 m)
0	32.2	28,300	46.5	18,300	60.7	8,900	60.6	14,100	75.0	5,600	75.0	9,500	89.2	3,400	89.1	6,700	103.0	2,000	102.0	4,900	117.0	800	116.0	3,300
Telescoping mode	I, II	I	I	II	I	II	I	II	I	II	I	II	I	II	I	II	I	II	I	II	I	II	I	II

- A : Boom length in feet
- B : Load radius in feet
- C : Loaded boom angle (°)
- D : Minimum boom angle (°) for indicated length (no load)

NOTE: The lifting capacity data stored in the LOAD MOMENT INDICATOR (AML-C) is based on the standard number of parts of line listed in the chart.
Standard number of parts of line for each boom length should be according to the following table.

Boom length in feet (meters)	39.4' (12 m)	39.4' to 68.1' (12 m to 20.8 m)		68.1' to 154.2' (20.8 m to 47 m)	Single top Jib
Telescoping mode	I, II	I	II	I, II	I, II
Number of parts of line	16	8	4	4	1

GR-1000XL RATED LIFTING CAPACITIES (IN POUNDS)

COUNTERWEIGHT 22,000 lbs (10 t)																														
ON OUTRIGGERS MID EXTENDED 18' 1/2" (5.5 m) SPREAD																														
360° ROTATION																														
B	39.4'		53.7'		68.1' (20.8 m)		82.4' (25.1 m)		96.8' (29.5 m)		111.1' (33.9 m)		125.5' (38.3 m)		139.8' (42.6 m)		154.2'													
	C	(12 m)	C	(16.4 m)	C		C		C		C		C		C		C	(47 m)												
8'	73	191,600	78	102,700																										
10'	70	164,000	76	102,700	80	90,200	79	40,100																						
12'	67	142,400	74	102,700	78	90,200	77	40,100																						
15'	61	113,500	70	102,700	75	89,900	75	40,100	78	42,500	78	35,500																		
20'	52	75,400	64	73,400	71	67,200	70	40,100	74	42,500	74	35,500	77	40,100	77	33,300	79	35,500	79	32,200										
25'	41	48,200	57	46,700	66	45,400	65	40,100	71	42,500	70	35,500	74	40,100	74	33,300	77	35,500	77	32,200	79	33,300	79	28,700						
30'	25	33,900	50	32,700	61	31,500	60	35,500	67	33,600	67	35,500	71	34,800	71	33,300	74	35,500	74	30,200	77	33,300	77	26,300	79	26,700	79	24,300		
35'			42	23,900	55	23,000	55	28,900	63	24,900	62	29,500	68	26,000	68	29,900	71	26,800	72	27,300	74	27,300	74	24,000	77	26,700	77	24,100	78	20,900
40'			33	18,000	50	17,100	50	22,800	58	19,000	58	23,400	64	20,100	64	23,800	68	20,800	69	24,100	71	21,400	72	22,000	74	21,800	75	22,300	77	20,900
45'			18	13,700	44	12,900	43	18,300	54	14,800	54	19,000	61	15,800	61	19,400	65	16,500	65	19,600	69	17,000	69	19,800	72	17,400	72	18,700	75	17,700
50'					36	9,700	36	14,900	49	11,500	49	15,600	57	12,600	57	16,000	62	13,200	62	16,300	66	13,800	67	16,400	70	14,100	70	15,300	73	14,400
55'					27	7,200	27	12,300	44	8,900	44	13,000	53	10,000	53	13,400	59	10,700	59	13,700	63	11,200	64	13,800	67	11,600	68	12,700	70	11,900
60'					12	5,300	12	10,300	38	6,900	38	10,800	49	7,900	49	11,300	55	8,600	56	11,600	61	9,100	61	11,700	65	9,500	65	10,700	68	9,800
65'									32	5,200	32	9,100	45	6,200	45	9,500	52	6,900	52	9,800	58	7,500	58	10,000	62	7,800	63	9,000	66	8,100
70'									23	3,800	23	7,700	40	4,800	40	8,100	48	5,500	49	8,300	55	6,000	55	8,500	60	6,400	60	7,500	64	6,700
75'									6	2,600	5	6,500	35	3,600	35	6,800	45	4,300	45	7,100	52	4,800	52	7,300	57	5,200	57	6,300	61	5,500
80'													29	2,600	28	5,800	41	3,200	41	6,000	49	3,700	49	6,200	55	4,100	55	5,200	59	4,400
85'													21	1,700	20	4,900	36	2,300	36	5,100	45	2,800	46	5,300	52	3,200	52	4,300	57	3,500
90'																	31	1,600	31	4,300	42	2,100	42	4,500	49	2,400	49	3,500	54	2,700
95'																			25	3,700	38	1,400	38	3,800	46	1,700	46	2,800	52	2,000
100'																			16	3,100			34	3,200	43	1,100	43	2,200	49	1,400
105'																							29	2,600			40	1,700		
110'																							23	2,200			36	1,100		
115'																							14	1,700						
D	0											18	0	29	0	40	27	47												
Telescoping conditions (%)																														
Telescoping mode	I, II	I	I	II	I	II	I	II	I	II	I	II	I	II	I	II	I, II													
2nd boom	0	50	100	0	100	0	100	0	100	0	100	0	100	0	100	50	100													
3rd boom	0	0	0	33	16	50	33	66	50	83	66	100	83	100	100	100														
4th boom	0	0	0	33	16	50	33	66	50	83	66	100	83	100	100															
Top boom	0	0	0	33	16	50	33	66	50	83	66	100	83	100	100															

COUNTERWEIGHT 22,000 lbs (10 t)																				
LIFTING CAPACITIES AT ZERO DEGREE BOOM ANGLE ON OUTRIGGERS MID EXTENDED																				
18' 1/2" (5.5 m) SPREAD 360° ROTATION																				
C	39.4'		53.7'		68.1'		82.4'		96.8'		111.1'		125.5'							
	B	(12 m)	B	(16.4 m)	B	(20.8 m)	B	(25.1 m)	B	(29.5 m)	B	(33.9 m)	B	(38.3 m)						
0	32.2	29,200	46.4	12,600	60.7	5,000	60.7	10,000	75.0	2,600	75.0	6,500	89.2	1,100	89.1	4,300	103.0	2,800	116.0	1,500
Telescoping mode	I, II	I	I	II	I	II	I	II	I	II	I	II	I	II						

- A : Boom length in feet
- B : Load radius in feet
- C : Loaded boom angle (°)
- D : Minimum boom angle (°) for indicated length (no load)

NOTE: The lifting capacity data stored in the LOAD MOMENT INDICATOR (AML-C) is based on the standard number of parts of line listed in the chart.
Standard number of parts of line for each boom length should be according to the following table.

Boom length in feet (meters)	39.4' (12 m)	39.4' to 68.1' (12 m to 20.8 m)	68.1' to 154.2' (20.8 m to 47 m)	Single top Jib
Telescoping mode	I, II	I II	I, II	I, II
Number of parts of line	16	8 4	4	1

GR-1000XL RATED LIFTING CAPACITIES (IN POUNDS)

COUNTERWEIGHT 22,000 lbs (10 t) ON OUTRIGGERS MID EXTENDED 18' 1 / 2" (5.5 m) SPREAD 360° ROTATION													
C	154.2' (47.0 m) Boom + 33.2' (10.1 m) Jib						C	154.2' (47.0 m) Boom + 58.1' (17.7 m) Jib					
	3.5° Tilt		25° Tilt		45° Tilt			3.5° Tilt		25° Tilt		45° Tilt	
	R	W	R	W	R	W		R	W	R	W	R	W
80	37.8'	10,800	51.5'	10,800	58.8'	9,400	80	45.8'	6,800	71.7'	6,300	83.5'	5,100
79	41.5'	10,800	55.3'	10,400	62.2'	9,200	79	50.0'	6,800	75.5'	6,200	87.1'	5,100
78	45.2'	10,800	58.6'	10,200	65.7'	9,000	78	54.2'	6,800	79.1'	6,000	90.3'	5,000
77	49.2'	10,800	62.1'	9,900	68.4'	8,800	77	58.5'	6,800	82.7'	5,900	93.3'	5,000
76	52.6'	10,800	65.3'	9,600	71.6'	8,700	76	62.7'	6,800	86.4'	5,800	96.2'	4,900
75	56.3'	10,800	69.0'	9,300	74.5'	8,500	75	66.8'	6,800	90.0'	5,700	99.5'	4,800
73	63.2'	10,100	74.4'	8,300	80.1'	7,600	73	74.6'	6,800	96.7'	5,500	105.0'	4,700
70	71.2'	7,400	82.4'	6,200	87.4'	5,700	70	84.5'	5,200	105.0'	4,200	112.0'	3,800
68	76.6'	6,000	87.3'	5,000	92.0'	4,700	68	90.3'	4,100	109.0'	3,300	117.0'	3,000
65	84.6'	4,300	95.2'	3,700	98.9'	3,500	65	98.8'	2,700	117.0'	2,300	123.0'	2,100
63	90.0'	3,400	100.0'	2,900	103.0'	2,800	63	105.0'	2,000	122.0'	1,700	128.0'	1,600
60	97.6'	2,300	107.0'	2,000	110.0'	1,900	60	113.0'	1,100				
58	103.0'	1,700	112.0'	1,400	115.0'	1,400							

COUNTERWEIGHT 22,000 lbs (10 t) ON OUTRIGGERS MID EXTENDED 18' 1 / 2" (5.5 m) SPREAD 360° ROTATION													
C	139.8' (42.6 m) Boom (telescoping mode II) + 33.2' (10.1 m) Jib						C	139.8' (42.6 m) Boom (telescoping mode II) + 58.1' (17.7 m) Jib					
	3.5° Tilt		25° Tilt		45° Tilt			3.5° Tilt		25° Tilt		45° Tilt	
	R	W	R	W	R	W		R	W	R	W	R	W
80	32.7'	11,700	45.8'	11,600	53.0'	10,000	80	40.8'	7,300	64.6'	6,500	77.3'	5,200
79	36.4'	11,700	49.0'	11,200	55.8'	9,800	79	44.7'	7,300	67.9'	6,400	80.4'	5,100
78	39.6'	11,700	52.1'	10,900	59.1'	9,600	78	48.7'	7,300	72.0'	6,200	83.5'	5,100
77	43.0'	11,700	55.0'	10,600	61.6'	9,400	77	52.6'	7,300	75.2'	6,100	86.2'	5,000
76	46.4'	11,700	57.7'	10,300	64.1'	9,200	76	56.5'	7,300	78.1'	6,000	89.2'	5,000
75	49.4'	11,700	60.9'	10,100	67.0'	9,100	75	60.0'	7,300	81.8'	5,900	92.4'	5,000
73	55.8'	11,500	67.0'	9,500	72.6'	8,700	73	67.0'	7,300	88.2'	5,700	97.7'	4,900
70	64.6'	10,200	74.9'	8,600	79.7'	7,800	70	78.3'	7,300	97.5'	5,400	105.0'	4,700
68	69.3'	8,500	79.7'	7,300	84.0'	6,700	68	83.8'	6,100	103.0'	5,000	110.0'	4,400
65	76.8'	6,600	86.4'	5,800	90.4'	5,400	65	91.6'	4,600	110.0'	3,900	116.0'	3,400
63	81.8'	5,600	91.1'	4,900	94.7'	4,600	63	97.1'	3,800	114.0'	3,200	120.0'	2,800
60	89.1'	4,300	97.6'	3,800	101.0'	3,600	60	105.0'	2,800	121.0'	2,400	127.0'	2,100
58	93.6'	3,600	102.0'	3,200	105.0'	3,000	58	110.0'	2,200	126.0'	1,900	131.0'	1,700
55	101.0'	2,700	108.0'	2,400	111.0'	2,300	55	118.0'	1,500	133.0'	1,300	137.0'	1,200
53	105.0'	2,200	113.0'	2,000	115.0'	1,900	53	123.0'	1,100				
50	111.0'	1,500	119.0'	1,400	120.0'	1,300							
48	116.0'	1,100	122.0'	1,000	124.0'	1,000							

COUNTERWEIGHT 22,000 lbs (10 t) ON OUTRIGGERS MID EXTENDED 18' 1 / 2" (5.5 m) SPREAD 360° ROTATION													
C	125.5' (38.3 m) Boom (telescoping mode I) + 33.2' (10.1 m) Jib						C	125.5' (38.3 m) Boom (telescoping mode I) + 58.1' (17.7 m) Jib					
	3.5° Tilt		25° Tilt		45° Tilt			3.5° Tilt		25° Tilt		45° Tilt	
	R	W	R	W	R	W		R	W	R	W	R	W
80	30.5'	14,600	43.5'	14,000	50.1'	10,700	80	37.2'	8,800	58.7'	7,000	71.2'	5,200
79	33.3'	14,600	46.0'	13,600	52.6'	10,600	79	41.2'	8,800	61.5'	6,800	73.9'	5,100
78	36.0'	14,600	49.2'	13,300	55.1'	10,500	78	44.8'	8,800	65.4'	6,700	76.8'	5,100
77	39.0'	14,600	51.7'	12,900	57.6'	10,300	77	47.8'	8,800	68.4'	6,500	79.5'	5,000
76	42.6'	14,600	54.1'	12,700	60.1'	10,200	76	51.3'	8,800	70.8'	6,400	82.1'	5,000
75	45.5'	14,600	56.9'	12,400	62.7'	10,100	75	54.9'	8,800	74.3'	6,300	84.9'	5,000
73	51.2'	14,600	62.4'	11,900	67.5'	10,000	73	61.6'	8,800	80.5'	6,100	90.0'	4,900
70	58.2'	11,300	68.9'	9,500	73.7'	8,600	70	71.3'	8,300	88.9'	5,800	97.5'	4,700
68	63.0'	9,500	73.2'	8,100	77.8'	7,400	68	76.1'	6,900	94.0'	5,500	102.0'	4,600
65	69.9'	7,300	79.6'	6,300	83.5'	5,900	65	84.0'	5,200	101.0'	4,200	108.0'	3,900
63	74.5'	6,100	83.7'	5,400	87.5'	5,000	63	89.2'	4,300	105.0'	3,500	112.0'	3,300
60	81.0'	4,700	90.0'	4,200	93.5'	3,900	60	96.6'	3,100	112.0'	2,600	118.0'	2,500
58	85.4'	3,900	93.9'	3,500	97.1'	3,300	58	102.0'	2,500	116.0'	2,100	122.0'	2,000
55	91.8'	2,900	99.7'	2,600	103.0'	2,500	55	108.0'	1,700	123.0'	1,400	128.0'	1,400
53	95.7'	2,300	104.0'	2,100	106.0'	2,000	53	113.0'	1,200	127.0'	1,000	131.0'	1,000
50	102.0'	1,600	109.0'	1,500	111.0'	1,400							
48	105.0'	1,100	113.0'	1,100	114.0'	1,000							

C : Loaded boom angle (°)
R : Load radius in feet
W : Rated lifting capacity in pounds

GR-1000XL RATED LIFTING CAPACITIES (IN POUNDS)

COUNTERWEIGHT 22,000 lbs (10 t) ON OUTRIGGERS MIN EXTENDED 8' 10-5 / 16" (2.7 m) SPREAD 360° ROTATION																												
B	A	39.4'		53.7'		68.1' (20.8 m)		82.4' (25.1 m)		96.8' (29.5 m)		111.1' (33.9 m)		125.5' (38.3 m)		139.8' (42.6 m)		154.2'										
	C	(12 m)	C	(16.4 m)	C	C	C	C	C	C	C	C	C	C	C	C	C	C	(47 m)									
8'	73	143,900	78	102,700																								
10'	70	94,900	76	93,000	80	90,200	79	40,100																				
12'	66	66,900	73	65,200	78	63,700	77	40,100																				
15'	61	44,700	70	43,400	75	42,000	75	40,100	78	42,500	78	35,500																
20'	52	26,300	64	25,400	70	24,300	70	30,400	74	26,400	74	31,000	77	27,500	77	31,400	79	28,300	79	31,700								
25'	41	17,000	57	16,100	65	15,300	65	20,900	70	17,200	70	21,500	74	18,200	74	21,800	76	18,900	76	22,100								
30'	25	11,400	50	10,400	60	9,600	60	14,900	66	11,600	66	15,700	70	12,500	70	16,000	73	13,200	73	16,200								
35'			42	6,600	55	5,800	55	10,900	62	7,700	62	11,600	67	8,700	67	12,100	70	9,400	70	12,300								
40'			33	3,900	49	3,100	49	8,100	58	4,900	58	8,700	63	5,900	64	9,200	67	6,600	68	9,500								
45'			18	1,800	43	1,100	43	5,900	53	2,800	53	6,500	60	3,700	60	7,000	64	4,500	64	7,300								
50'							36	4,300	49	1,100	49	4,900	56	2,100	56	5,300	61	2,800	61	5,600								
55'							27	2,900			44	3,500			53	3,900	58	1,500	58	4,200								
60'							13	1,900			38	2,400			49	2,800			55	3,100								
65'											31	1,500			44	1,900			52	2,200								
70'											40	1,100			48	1,400			54	1,500								
D		0		28		0		44		5		49		35		55		45		58		52		62		57		65
Telescoping conditions (%)																												
Telescoping mode	I, II	I	I	II	I	II	I	II	I	II	I	II	I	II	I	II	I	II	I, II									
2nd boom	0	50	100	0	100	0	100	0	100	0	100	0	100	0	100	0	100	50	100									
3rd boom	0	0	0	33	16	50	33	66	50	83	66	100	83	100	83	100	100											
4th boom	0	0	0	33	16	50	33	66	50	83	66	100	83	100	83	100	100											
Top boom	0	0	0	33	16	50	33	66	50	83	66	100	83	100	83	100	100											

COUNTERWEIGHT 22,000 lbs (10 t) LIFTING CAPACITIES AT ZERO DEGREE BOOM ANGLE ON OUTRIGGERS MIN EXTENDED 8' 10-5 / 16" (2.7 m) SPREAD 360° ROTATION																			
C	A	39.4'		53.7'		68.1'													
	B	(12 m)	B	(16.4 m)	B	(20.8 m)													
0	32.2'	9,200	46.5'	1,300		60.8'	1,700												
Telescoping mode	I, II	I		II															

NOTE: The lifting capacity data stored in the LOAD MOMENT INDICATOR (AML-C) is based on the standard number of parts of line listed in the chart.
Standard number of parts of line for each boom length should be according to the following table.

Boom length in feet (meters)	39.4' (12 m)	39.4' to 68.1' (12 m to 20.8 m)		68.1' to 154.2' (20.8 m to 47 m)	Single top Jib
Telescoping mode	I, II	I	II	I, II	I, II
Number of parts of line	16	8	4	4	1

- A : Boom length in feet
- B : Load radius in feet
- C : Loaded boom angle (°)
- D : Minimum boom angle (°) for indicated length (no load)

WITHOUT COUNTERWEIGHT ON OUTRIGGERS FULLY EXTENDED 23' 11-3 / 8" (7.3 m) SPREAD 360° ROTATION				
B	A	39.4'		68.1'
	C	(12 m)	C	(20.8 m)
8'	73		26,500	
10'	70		26,500	
12'	66		26,500	79
15'	61		26,500	75
20'	52		26,500	71
25'	41		26,500	67
30'	26		26,500	62
35'				57
40'				51
45'				45
50'				38
55'				29
60'				15
D				0
Telescoping conditions (%)				
Telescoping mode		I, II		II
2nd boom		0		0
3rd boom		0		33
4th boom		0		33
Top boom		0		33

NOTE: The lifting capacity data stored in the LOAD MOMENT INDICATOR (AML-C) is based on the standard number of parts of line listed in the chart.
Standard number of parts of line for each boom length should be according to the following table.

Boom length in feet (meters)	39.4' (12 m)	68.1' (20.8 m)
Telescoping mode	I, II	II
Number of parts of line		4

- A : Boom length in feet
- B : Load radius in feet
- C : Loaded boom angle (°)
- D : Minimum boom angle (°) for indicated length (no load)

WARNING AND OPERATING INSTRUCTIONS FOR LIFTING CAPACITIES

GENERAL

1. RATED LIFTING CAPACITIES apply only to the machine as originally manufactured and normally equipped by TADANO LTD. Modifications to the machine or use of optional equipment other than that specified can result in a reduction of capacity.
2. Hydraulic cranes can be hazardous if improperly operated or maintained. Operation and maintenance of this machine must be in compliance with information, in the **Operation and Maintenance Manual** supplied with the crane. If this manual is missing, order a replacement through the distributor.
3. The operator and other personnel associated with this machine shall fully acquaint themselves with the latest American National Standards Institute (ANSI) safety standards for cranes.

SET UP

1. Rated lifting capacities on the chart are the maximum allowable crane capacities and are based on the machine standing level on firm supporting surface under ideal job conditions. Depending on the nature of the supporting surface, it may be necessary to have structural supports under the outrigger floats or tires to spread the loads to a larger bearing surface.
2. For outrigger operation, outriggers shall be properly extended with tires free of supporting surface before operating crane.

OPERATION

1. Rated lifting capacities have been tested to and meet minimum requirements of SAE J1063-Cantilevered Boom Crane Structures Method of Test.
2. Rated lifting capacities do not exceed 85 % of the tipping load on outriggers fully extended as determined by SAE J765-Crane Stability Test Code.
Rated lifting capacities for partially extended outriggers are determined from the formula, Rated Lifting Capacities = (Tipping Load - 0.1 x Tip Reaction) / 1.25.
3. Rated lifting capacities above thick lines in the chart are based on crane strength and those below, on its stability. They are based on actual load radius increased by boom deflection.
4. The weight of handling device such as hook blocks, slings, etc., must be considered as part of the load and must be deducted from the lifting capacities.
5. Rated lifting capacities are based on freely suspended loads and make no allowance for such factors as the effect of wind, sudden stopping of loads, supporting surface conditions, inflation of tires, operating speeds, side loads, etc. Side pull on the boom or jib is extremely dangerous. Such action can damage the boom, jib or slewing mechanism, and lead to overturning of the crane.
6. Rated lifting capacities do not account for wind on lifted load or boom. We recommend against working under the condition that the load is out of control due to a strong wind. During boom lift, consider that the rated lifting capacity is reduced by 50 % when the wind speed is 20 mph (9 m/s) to 27 mph (12 m/s); reduced by 70 % when the wind speed is 27 mph (12 m/s) to 31 mph (14 m/s). If the wind speed is 31 mph (14 m/s) or over, stop operation. During jib lift, stop operation if the wind speed is 20 mph (9 m/s) or over.
7. Rated lifting capacities at load radius shall not be exceeded. Do not tip the crane to determine allowable loads.
8. Do not operate at boom lengths, radii, or boom angle, where no capacities are shown. Crane may overturn without any load on the hook.
9. When boom length is between values listed, refer to the rated lifting capacities of the next longer and next shorter booms for the same radius. The lesser of the two rated lifting capacities shall be used.

10. When making lifts at a load radius not shown, use the next longer radius to determine allowable capacity.
11. Load per line should not exceed 14,600 lbs. (6,600 kg) for main winch and auxiliary winch.
12. Check the actual number of parts of line with LOAD MOMENT INDICATOR (AML-C) before operation. Maximum lifting capacity is restricted by the number of parts of line of LOAD MOMENT INDICATOR (AML-C). Limited capacity is as determined from the formula, Single line pull for main winch 14,600 lbs. (6,600 kg) x number of parts of line.
13. The boom angle before loading should be greater to account for deflection. For rated lifting capacities, the loaded boom angle and the load radius is for reference only.
14. The 39.4' (12.0 m) boom length capacities are based on boom fully retracted. If not fully retracted [less than 53.7' (16.4 m) boom length], use the rated lifting capacities for the 53.7' (16.4 m) boom length.
15. Extension or retraction of the boom with loads may be attempted within the limits of the RATED LIFTING CAPACITIES. The ability to telescope loads is limited by hydraulic pressure, boom angle, boom length, crane maintenance, etc.
16. For lifting capacity of single top, deduct the weight of the load handling equipment from the rated lifting capacity of the boom. For the lifting capacity of single top, the net capacity shall not exceed 14,600 lbs. (6,600 kg) including main boom hook mass attached to the boom.
17. When the base jib or top jib or both jibs are removed, set the jib state switch to the REMOVED position.
18. When erecting and stowing jib, be sure to retain it by hand or by other means to prevent its free movement.
19. Use "ANTI-TWO BLOCK" disable switch when erecting and stowing jib and when stowing hook block. While the switch is pushed, the hoist does not stop, even when overwind condition occurs.
20. For boom length 154.2' (47.0 m) or less and 125.5' (38.3 m) or longer with jib, rated lifting capacities are determined by loaded boom angle only in the column headed "154.2' (47.0 m) boom + jib".

For boom length 125.5' (38.3 m) or less with jib, rated lifting capacities are determined by loaded boom angle only in the column headed "125.5' (38.3 m) boom + jib". For angles not shown, use the next lower loaded boom angle to determine allowable capacity. (Telescoping MODE I)
For boom length 154.2' (47.0 m) or less and 139.8' (42.6 m) or longer with jib, rated lifting capacities are determined by loaded boom angle only in the column headed "154.2' (47.0 m) boom + jib".
For boom length 139.8' (42.6 m) or less with jib, rated lifting capacities are determined by loaded boom angle only in the column headed "139.8' (42.6 m) boom + jib". For angles not shown, use the next lower loaded boom angle to determine allowable capacity. (Telescoping MODE II)

21. When lifting a load by using jib (aux. winch) and boom (main winch) simultaneously, do the following:
 - Enter the operation status as jib operation, not as boom operation.
 - Before starting operation, make sure that mass of load is within rated lifting capacity for jib.
22. Before telescoping the boom, set the telescoping mode selector switch to MODE I or MODE II with the boom fully retracted. A change of the telescoping mode is not permissible when the boom has been partially or fully extended.
23. Crane operation is prohibited without full counterweight 22,000 lbs. (10 tons) installed. Outriggers shall be extended 23'11 3/8" (7.3 m) spread when installing or removing removable counterweight.

DEFINITIONS

1. Load Radius: Horizontal distance from a projection of the axis of rotation to supporting surface before loading to the center of the vertical hoist line or tackle with load applied.
2. Loaded Boom Angle: The angle between the boom base section and the horizontal, after lifting the rated lifting capacity at the load radius.
3. Working Area: Area measured in a circular arc about the centerline of rotation.
4. Freely Suspended Load: Load hanging free with no direct external force applied except by the hoist line.
5. Side Load: Horizontal side force applied to the lifted load either on the ground or in the air.

GR-1000XL RATED LIFTING CAPACITIES (IN POUNDS)

COUNTERWEIGHT 22,000 lbs (10 t) ON-RUBBER STATIONARY												
B \ A	Over Front						360° Rotation					
	39.4'		68.1'		96.8'		39.4'		68.1'		96.8'	
	C	(12 m)	C	(20.8 m)	C	(29.5 m)	C	(12 m)	C	(20.8 m)	C	(29.5 m)
12'	66	60,000					66	38,000				
15'	61	49,600					61	28,500				
20'	52	37,500	70	35,000			52	17,500	70	20,000		
25'	41	28,500	65	29,500	74	22,900	40	10,400	65	14,000	73	14,000
30'	25	21,500	60	24,000	71	21,500	25	6,500	60	9,500	70	10,000
35'			55	19,200	67	19,500			55	6,500	67	7,400
40'			49	15,200	64	16,000			49	4,500	63	5,400
45'			43	12,200	60	13,000			43	3,000	60	3,900
50'			36	9,700	57	10,600			36	1,800	56	2,700
55'			27	8,000	53	8,800					53	1,700
60'			13	6,500	49	7,400						
65'					45	6,100						
70'					40	5,000						
75'					35	4,100						
80'					28	3,400						
85'					20	2,700						
D	0						0		28		45	
Telescoping conditions (%)												
Telescoping mode	I, II		II		II		I, II		II		II	
2nd boom	0		0		0		0		0		0	
3rd boom	0		33		66		0		33		66	
4th boom	0		33		66		0		33		66	
Top boom	0		33		66		0		33		66	

LIFTING CAPACITIES AT ZERO DEGREE BOOM ANGLE ON-RUBBER STATIONARY												
C \ A	Over Front						360° Rotation					
	39.4'		68.1'		96.8'		39.4'		68.1'		96.8'	
	B	(12 m)	B	(20.8 m)	B	(29.5 m)	B	(12 m)				
0	32.2'	19,300	60.8'	6,300	89.1'	2,100	32.2'	5,100				

COUNTERWEIGHT 22,000 lbs (10 t) ON-RUBBER CREEP												
B \ A	Over Front											
	39.4'		68.1'		96.8'							
	C	(12 m)	C	(20.8 m)	C	(29.5 m)						
12'	66	45,000										
15'	61	36,600										
20'	52	26,800	70	29,200								
25'	40	20,500	65	22,800	74	22,900						
30'	25	15,600	60	18,200	71	18,900						
35'			55	14,800	67	15,500						
40'			49	12,000	64	12,900						
45'			43	9,800	60	10,600						
50'			36	7,900	57	8,900						
55'			27	6,500	53	7,300						
60'			13	5,200	49	6,100						
65'					44	5,000						
70'					40	4,100						
75'					34	3,200						
80'					28	2,500						
D	0											
Telescoping conditions (%)												
Telescoping mode	I, II		II		II							
2nd boom	0		0		0							
3rd boom	0		33		66							
4th boom	0		33		66							
Top boom	0		33		66							

LIFTING CAPACITIES AT ZERO DEGREE BOOM ANGLE ON-RUBBER CREEP												
C \ A	Over Front											
	39.4'		68.1'		96.8'							
	B	(12 m)	B	(20.8 m)	B	(29.5 m)						
0	32.2'	14,100	60.8'	5,000	89.1'	1,400						

- A** : Boom length in feet
- B** : Load radius in feet
- C** : Loaded boom angle (°)
- D** : Minimum boom angle (°) for indicated length (no load)

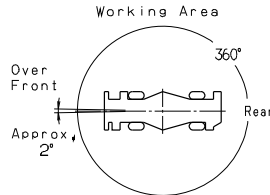

NOTE: The lifting capacity data stored in the LOAD MOMENT INDICATOR (AML-C) is based on the standard number of parts of line listed in the chart. Standard number of parts of line for on-rubber operation should be according to the following table.

Boom length in feet (meters)	39.4' (12 m)	39.4' to 96.8' (12 m to 29.5 m)	Single top Jib
Number of parts of line	6	4	1

WARNING AND OPERATING INSTRUCTIONS FOR ON-RUBBER LIFTING CAPACITIES

- Rated lifting capacities on-rubber are in pounds and do not exceed 75 % of tipping loads as determined by SAE J765-Crane Stability Test Code.
- Rated lifting capacities shown in the chart are based on condition that crane is set on firm level surfaces with suspension-lock applied. Those above thick lines are based on tire capacity and those below, on crane stability. They are based on actual load radius increased by tire deformation and boom deflection.
- If the suspension-lock cylinders contain air, the axle will not be locked completely and rated lifting capacities may not be obtainable. Bleed the cylinders according to the operation safety and maintenance manual.
- Rated lifting capacities are based on proper tire inflation, capacity and condition. Damaged tires are hazardous to safe operation of crane.
- Tires shall be inflated to correct air pressure.
- Over front operation shall be performed within 2 degrees in front of chassis.
- On-rubber lifting with "jib" is not permitted. Maximum permissible boom length is 96.8' (29.5 m).
- When making lift on-rubber stationary, set parking brake.
- For creep operation, boom must be centered over front of machine, slewing lock engaged, and load restrained from slewing. Travel slowly and keep the lifted load as close to the ground as possible, and especially avoid any abrupt steering, accelerating or braking
- Do not operate the crane while carrying the load
- Creep is motion for crane not to travel more than 200' (60 m) in any 30 minute period and to travel at the speed of less than 1 mph (1.6 km/h).
- For creep operation, choose the drive mode and proper gear according to the road or working condition.

Tires	Air Pressure
29.5-25 34 PR	57 psi (400 kPa)

WARNING AND OPERATING INSTRUCTIONS FOR USING THE LOAD MOMENT INDICATOR (AML-C)

- Set AML select keys in accordance with the actually operating crane conditions and don't fail to make sure, before crane operation, that the displays on front panel are correct.
 - When operating crane on outriggers:
 - Set P.T.O. switch to "ON".
 - Press the outrigger state select key to register for the outrigger operation. If the display agrees with the actual state, press the set key to register. After the completion of the registration, the pop-up window closes.
 - Press the lift state select key to register the lift state to be used (single top / jib / boom).
 - Each time the lift state select key is pressed, the display changes. If the display agrees with the actual state, press the set key to register. After the completion of the registration, the pop-up window closes.
 - when erecting and stowing jib, select the status of jib set (Jib lift indicator symbol flickers).
 - When operating crane on-rubber:
 - Set P.T.O. switch to "ON".
 - Press the outrigger state select key to register for the on-rubber operation. Each time the outrigger state select key is pressed the display changes. Select the creep operation, the on-rubber state indicative symbol flickers.
 - Press the lift state select key to register the lift state.
- However, pay attention to the following
- For stationary operation.
 - The front capacities are attainable only when the over front position symbol comes on. When the boom is more than 2 degrees from centered over front of chassis, 360° capacities are in effect.
 - When a load is lifted in the front position and then slewed to the side area, make sure the value of the LOAD MOMENT INDICATOR (AML-C) is below the 360° lifting capacity.
 - For creep operation.
 - The creep capacities are attainable only when boom is in the straight forward position of chassis and the over front position symbol is on. If boom is not in the straight forward position of chassis, never lift load.
 - This machine is equipped with an automatic slewing stop device (For the details, see Operation and Maintenance Manual.) But, operate very carefully because the automatic slewing stop does not work in the following case.
 - During on-rubber operation.
 - When the "P.T.O" switch is set to "OVERRIDE" and the "OVERRIDE" key switch outside the cab is on.
 - During crane operation, make sure that the displays on front panel are in accordance with actual operating conditions
 - The displayed values of LOAD MOMENT INDICATOR (AML-C) are based on freely suspended loads and make no allowance for such factors as the effect of wind, sudden stopping of loads, supporting surface conditions, inflation of tire, operating speed, side loads, etc. For safe operation, it is recommended when extending and lowering boom or slewing, lifting loads shall be appropriately reduced.
 - LOAD MOMENT INDICATOR (AML-C) is intended as an aid to the operator. Under no condition should it be relied upon to replace use of capacity charts and operating instruction. Sole reliance upon LOAD MOMENT INDICATOR (AML-C) aids in place of good operating practice can cause an accident. The operator must exercise caution to assure safety.
 - The lifting capacity differs depending on the outrigger extension width and slewing position. Work with the capacity corresponding to the outrigger extension width and slewing position. For the relationship among the outrigger extension width slewing position and lifting capacities, refer to the working area charts.

GR-1000XL Axle Weight Distribution Chart

	Pounds			Kilograms		
	GVW	Front	Rear	GVW	Front	Rear
Base machine	115,610	57,340	58,270	52,440	26,010	26,430
Remove:						
1.7.3 ton (6.6 metric ton) hook block	-360	-515	155	-165	-235	70
2.100 ton (90.7 metric ton) hook block	-1,900	-3,665	1,765	-862	-1,664	802
3.Top jib	-740	-990	250	-336	-450	114
4.Base jib	-1,910	-3,755	1,845	-867	-1,704	837
5.Auxiliary lifting sheave	-110	-330	220	-50	-149	99
6.Removable Counterweight (with Auxiliary Winch&wire rope)	-22,000	9,350	-31,350	-9,979	4,240	-14,219



TADANO AMERICA Corporation

4242 West Greens Road.
Houston, Texas 77066
PHONE: (281) 869-0030
FAX: (281) 869-0040
www.tadanoamerica.com